

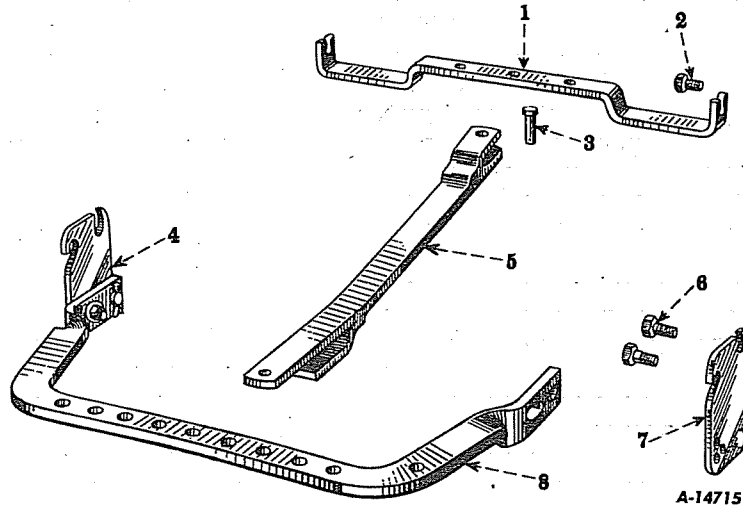

CHASSIS



Reference numbers only are shown in illustration. Use I H part numbers in ordering.

DRAWBAR

1	351 433 RI	BAR, ANCHOR, SWINGING DRAWBAR (SPECIAL)	1
2	351 679 RI	BOLT, SWINGING DRAWBAR ANCHOR BAR (SPECIAL)	2
3	Q 3 558	PIN, SWINGING DRAWBAR PIVOT (SPECIAL)	1
	103 408	PIN, COTTER, 3/16 x 1-1/4"	1
4	350 964 R11	BRACKET, QUICK ATTACHABLE DRAWBAR, L.H.	1
	103 419	PIN, COTTER, 1/4 x 1-1/4"	1
5	351 430 R11	DRAWBAR, SWINGING (SPECIAL)	1
6	351 679 RI	BOLT, DRAWBAR BRACKET	4
7	350 965 R11	BRACKET, QUICK ATTACHABLE DRAWBAR, R.H.	1
	103 419	PIN, COTTER, 1/4 x 1-1/4"	1
8	350 963 RI	DRAWBAR, QUICK ATTACHABLE	1
	220 068	NUT, HEX., 1/2-13NC	2
	179 887	SCREW, CAP, HEX-HD., 1/2-13NC x 1-3/4"	2
	103 323	WASHER, LOCK, 1/2"	2
	106 265	WASHER, PLAIN, 1/2"	2
	351 429 R91	ATTACHMENT, SWINGING DRAWBAR (SPECIAL) (MACHINE ATTACHMENT)	1
	352 714 RI	SPACER, DRAWBAR ANCHOR BAR	x
	352 752 RI	SPACER, DRAWBAR ANCHOR BAR	x